

# Skeleton Log Car

Nelson Riedel, [Nelson@NelsonsLocomotive.com](mailto:Nelson@NelsonsLocomotive.com)  
11/07/2012, last updated 11/10/2012

Log Car

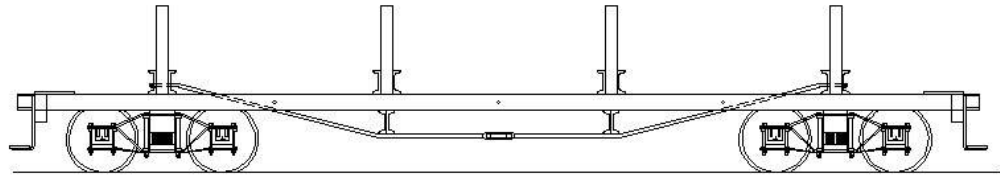
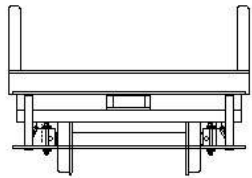
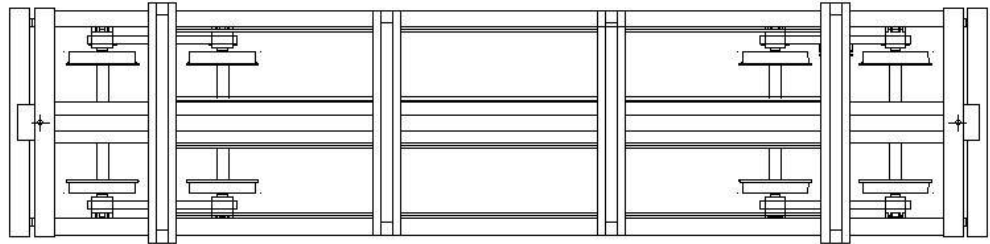

The drawing above shows the assembled Skeleton Log Car. It is 5' long at the ends of the coupler pockets and 15" wide at the log bunks. The long pieces are 1" square tubes. The more typical way to make a car is to use a 1" X 2" tube down the center the ends of which are the coupler pockets. I wanted to simulate a car made with wood beams so the 1" square tubes simulating 8" X 8" timbers looked better to me. The center three tubes can be replaced with a single 1" X 2" tube with no loss of strength.

The car was constructed in segments and the description below follows that sequence: the Tubes, the Car Ends, the Log Bunks, the I beams and the Truss Rods.

## The Tubes:

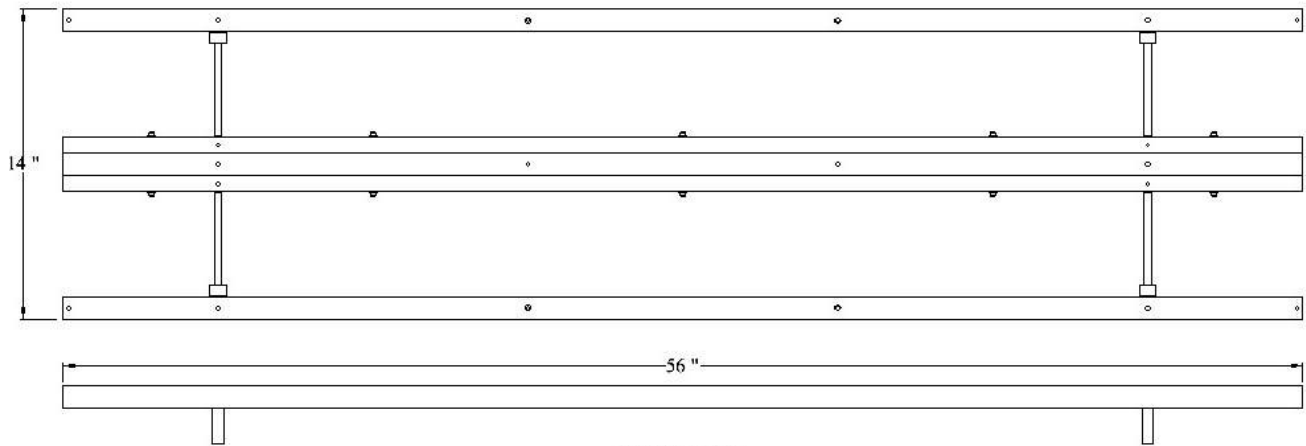

The diagram above shows the 5 tubes. All the tubes are 1" square and 56" inches long. I used 1/16" wall tubes that I had on hand for the outside tubes and the center tube and 1/8" wall on the other 2 tubes on the first car I built. Screws that attach the I beam go into threaded holes in the outside bar. Those threaded holes can be easily stripped out of the 1/16" thick tube wall; I plan to use 3/32" or 1/8" walls for those tubes on the next car.

The three tubes in the center are connected together with five 8-32 threaded rods with flat washers and nuts on the ends. These three tubes are considered together as a unit in drawings below.

The Rollers shown in diagram on right rest against the Car Support Blocks on the ends of the truck Upper Spring Plank. The use of rollers is similar to the design of the frame on the Heisler Locomotive and is probably overkill on a log car.

The Truck Pins shown on the right are attached to the center tube and fit into the sleeve bearing in the center of the truck Upper Spring Plank.

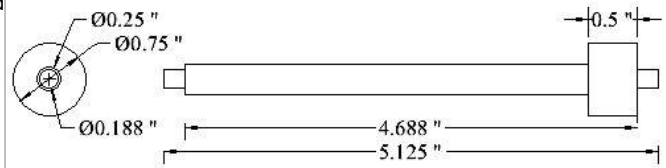

Roller with Axel - 4 Reqd

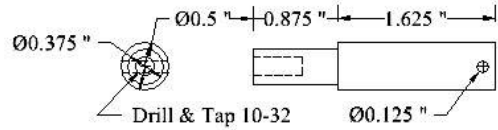

Truck Pin - 2 Reqd

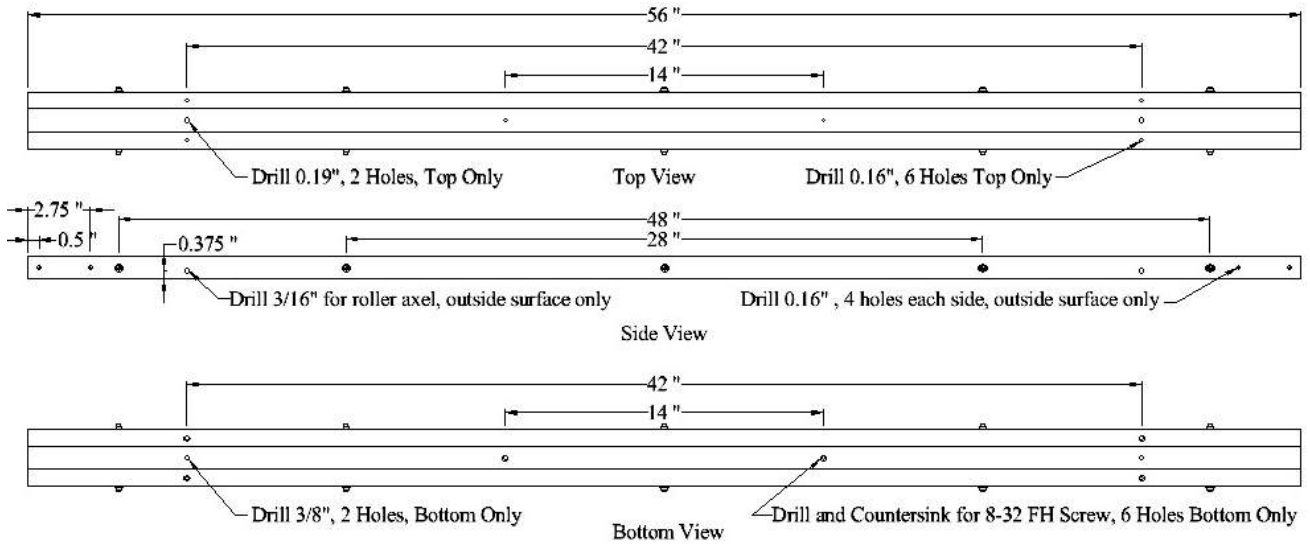

## Center Tubes

The diagram above shows the center tubes as a single unit. The 0.19" holes at each end are for 10-32 screws into the Truck Pins which slide into the 3/8" holes in the under side. The 6 - 0.16" holes in the top with mating countersunk holes on the bottom are for 8-32 FH screws that go through the tube and into threaded holes in the log bunks. The 0.16" holes in the sides are for 8-32 screws into mating threaded holes in the Coupler Pocket Bars that attach the Car Ends to the Center Tube Unit. Not shown are 8-32 threaded holes used to attach the I Beams and Car Ends to the Tubes. Holes in the Car Ends and I Beams are used to spot those holes which are then drilled and tapped.

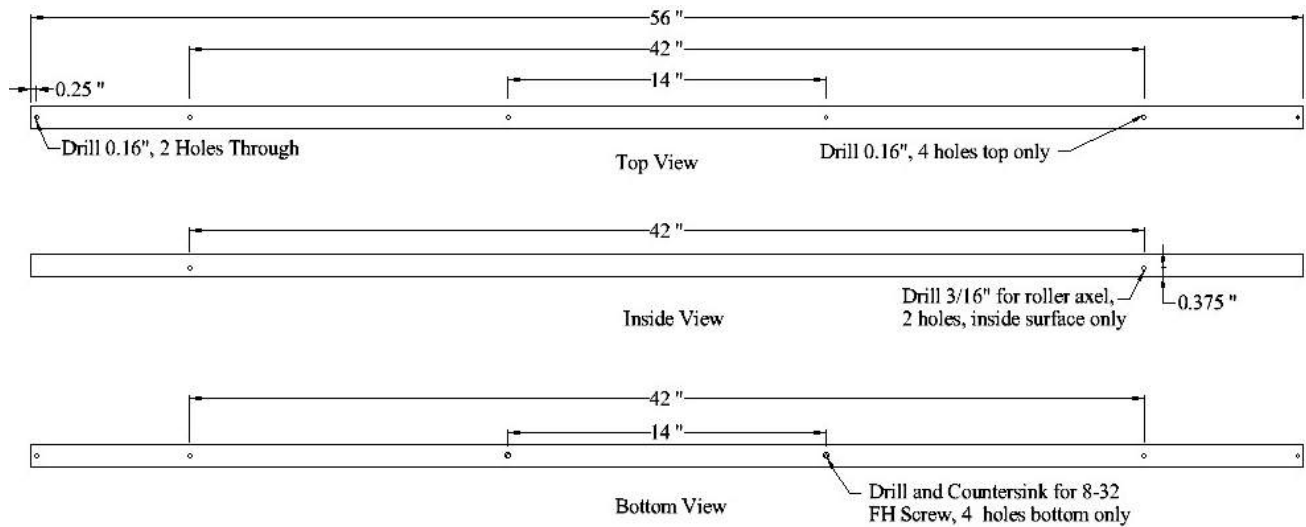

## Outside Tubes - 2 Reqd

The diagram above shows an Outside Tube (2 are required). The 4 0.16" holes in the top with mating countersunk holes on the bottom are for 8-32 FH screws that go through the tube and into threaded holes in the log bunks. The 0.16" through holes near the ends of the tubes are for screws and nuts that attach the Car Ends to the Outside tubes. Not shown are 8-32 threaded holes used to attach the I Beams to the Outside Tubes. Holes in the I Beams are used to spot these holes which are then drilled and tapped.



Photo above shows the tubes ready for the attachment of the car ends.

### Car Ends:

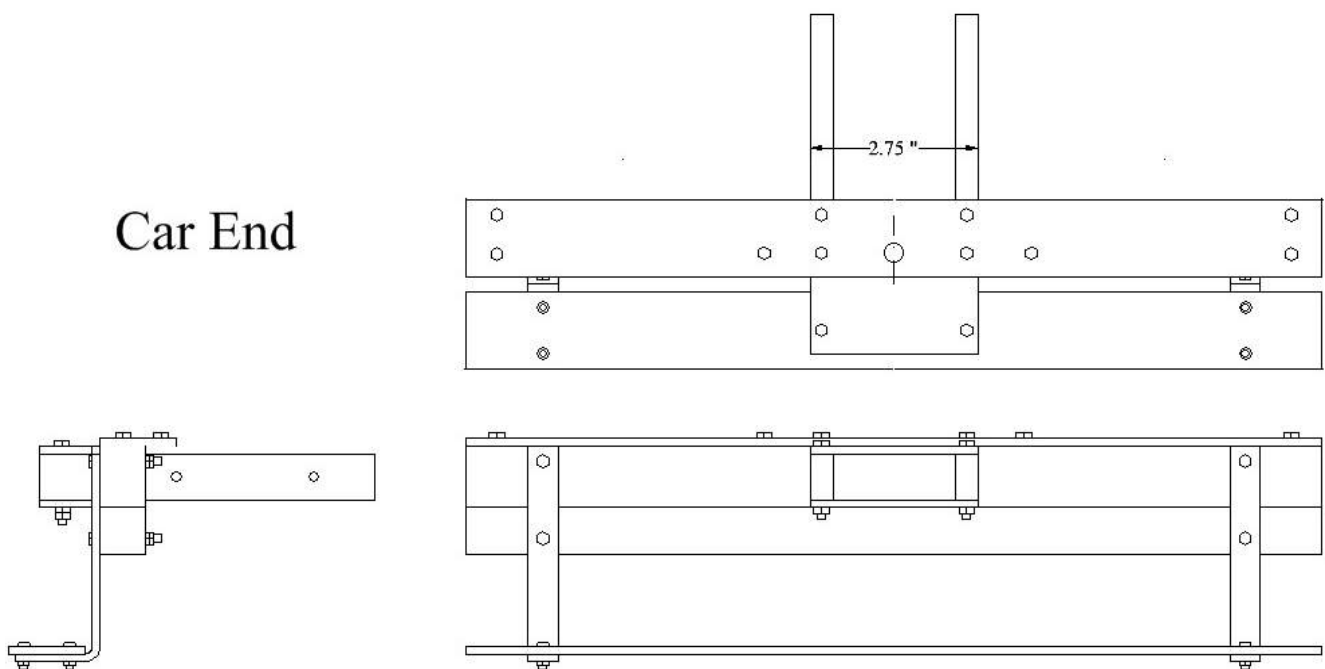

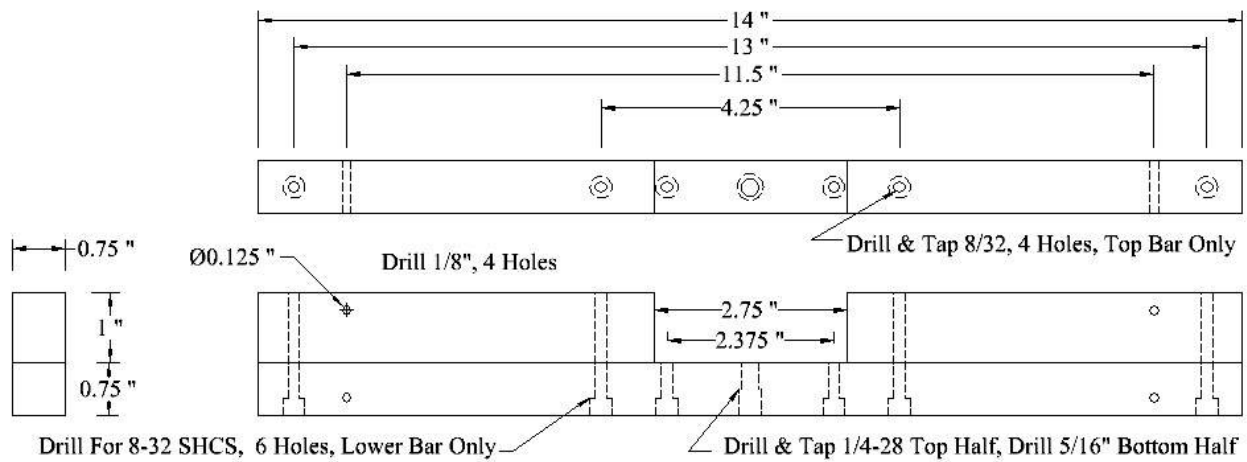

Car End Bars

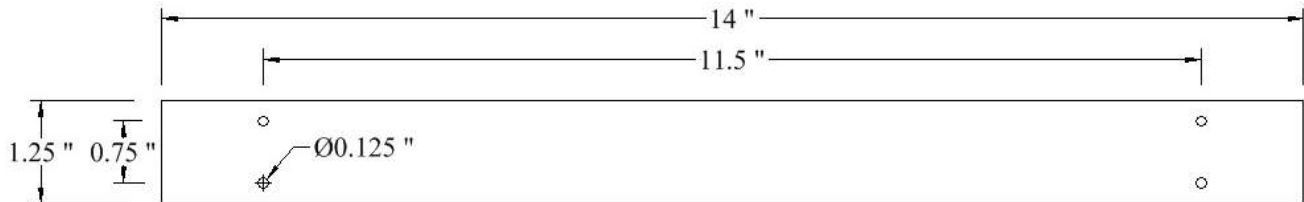

Foot Board - 1/8" HRS Barstock

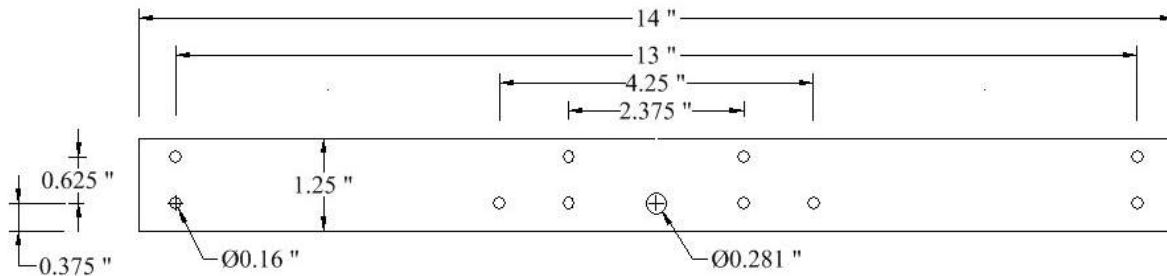

Deck Board - 1/8" HRS Barstock

The 3 Car End Bars are shown together on the drawing above. Once the four 8-32 SHCS that tie the bars together are installed they can be treated as a single bar.

The End Attachment Bars are 5 1/2" lengths of 3/8" X 3/4" CFS bar stock drilled and tapped as shown on the drawing at right. Note that the corners of the bars that fit inside the tubes are rounded to match the rounded corners on the inside of the tubes. The bench grinder was used to round the corners

The Coupler Plates of 1/8" HRS bar stock were drilled as shown in drawing on the right.

The next step is to attach the Coupler Plates to the End Attachment Bars using 6/32 screws and nuts. The screws are through the only non threaded holes in the End Attachment Bars.

The 1/8" X 1/2" CFS bar stock for the Foot Board Brackets were cut extra long. The bend was made by clamping the bars in a large vise and pounding the end over using a large hammer. The brackets were

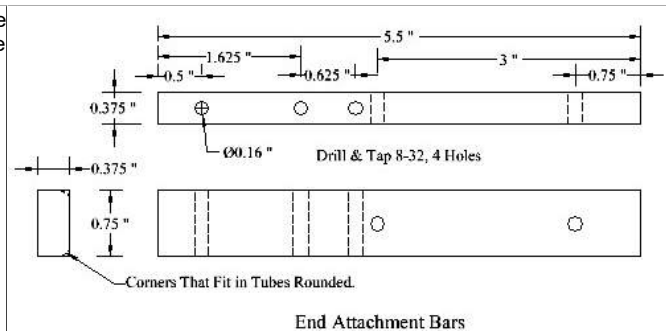

End Attachment Bars

clamped in the correct position on the End Bars and the holes for the attachment screws were spotted using the holes in the End Bars. Those holes were then drilled and the brackets attached to the End Bars. Next, the Foot Board was clamped in the correct position to the Brackets and the holes in the Foot Board used to spot the holes in the Brackets. The correct length for the Brackets was marked after the Brackets with Foot Board were attached to the End Bars

The last step in the assembly of the Car End is to attached the Deck Board using 8/32 hex head screws.

The Attachment Bars are then slid into the ends of the Center Tube Unit and attached with 8/32 hex head screws through the sides of the tubes into the sides of the End Attachment Bars.

The outside tubes are then attached to the Car Ends using an 8-32 hex head screw and nut through the end of the Deck Board into each end of each Outside Tube. Note that the ends of the roller axels must be inserted in holes in the sides of the Center Tube Unit and the Outside Tubes before the Outside Tubes are attached.

A photo of the completed Car Ends is below. Note that the Car Ends are fitted with Safety Chain Eyes and Air Brake Hose Fittings. The Safety Chains and Brakes are described elsewhere.

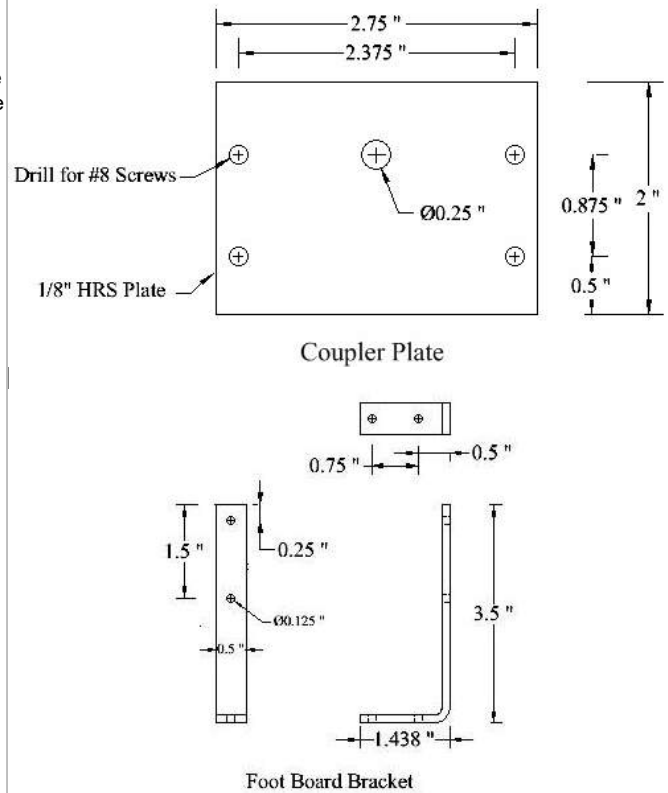

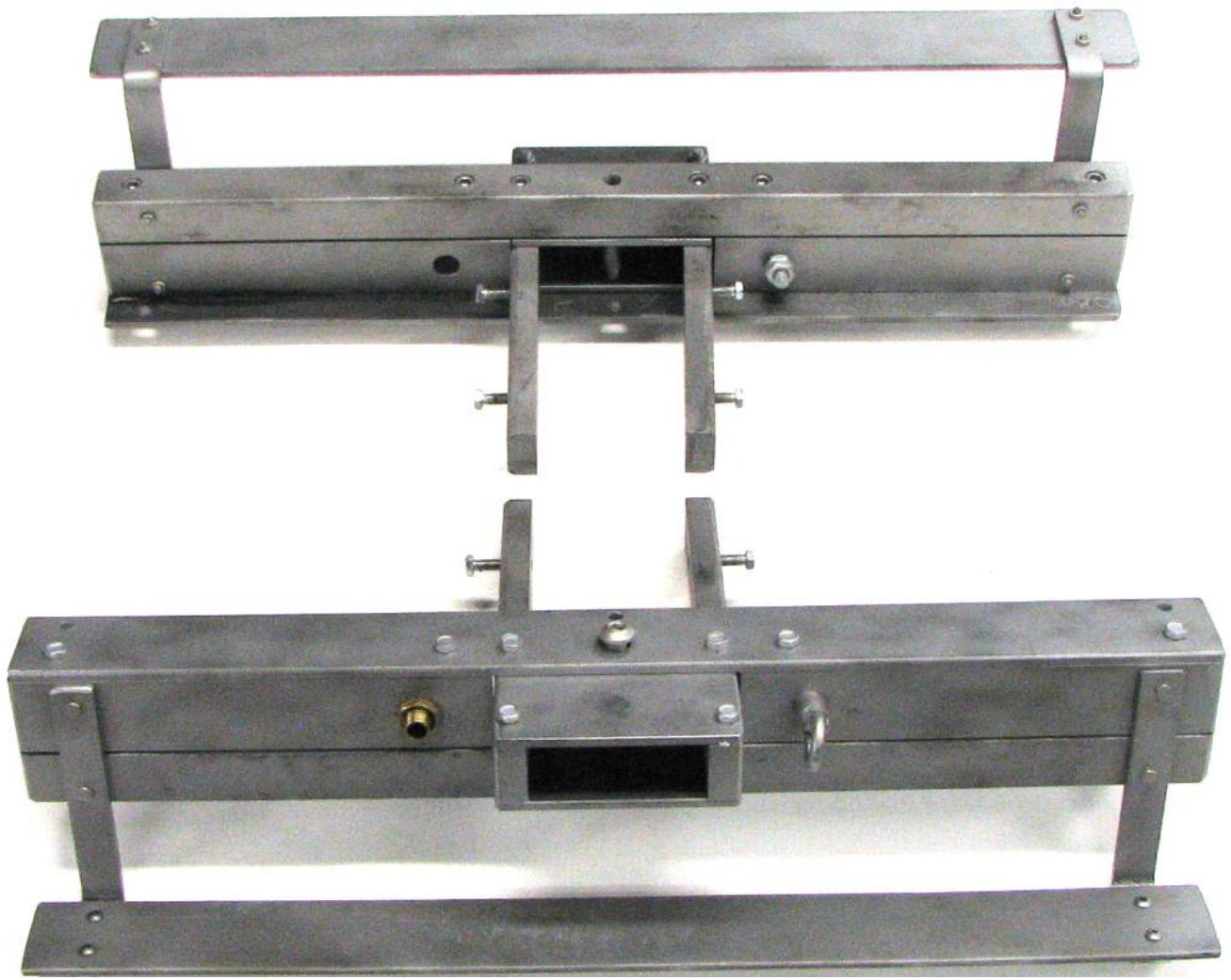

Inside Log Bunk:

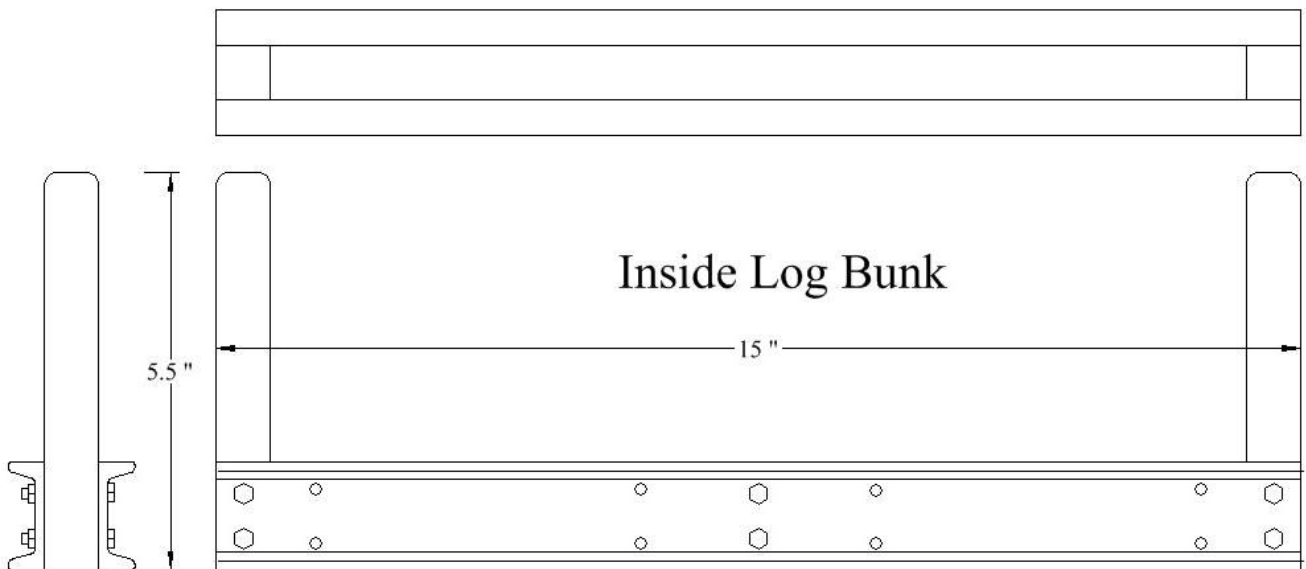

The Inside Log Bunks are essentially identical to the Log Bunk on the Disconnected Log Trucks except the Truck Pin is omitted and the Filler Tubes run the entire length between the End Posts.

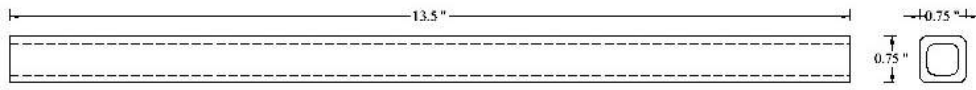
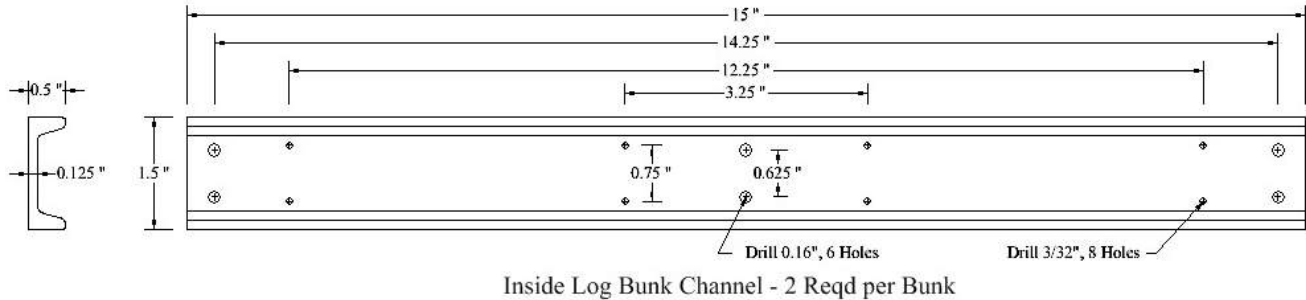

The Log Bunk Channels and End Posts are cut and drilled per the drawings. The Ends Posts are then sandwiched between a pair of Channels and secured with 8-32 hex head screws with nuts. The Filler Tubes are cut to be a very tight fit between the End Post and driven into position. The Channels are then used as a drill template for the 8/32 screw holes in the center. Those screws with nuts are then installed to hold the tubes in position. Then 0.089" holes are drilled into the tubes through the 3/32 holes in the channels. #2 drive screws are then pounded into those holes. The Log Bunks are attached to the Car Tubes with 8/32 FH screws up though the tubes into holes in the Log Bunk Filler Tubes. The Log Bunks are clamped into position on the previously assembled Tubes and Car Ends and the holes in the tubes used to spot the holes for the attachment screws in the Filler tubes. The holes in the filler Tubes are then drilled and tapped 8-32 and the Log Bunks are then attached to the Car Tubes. The photo below shows the assembled Inside Log Bunks.

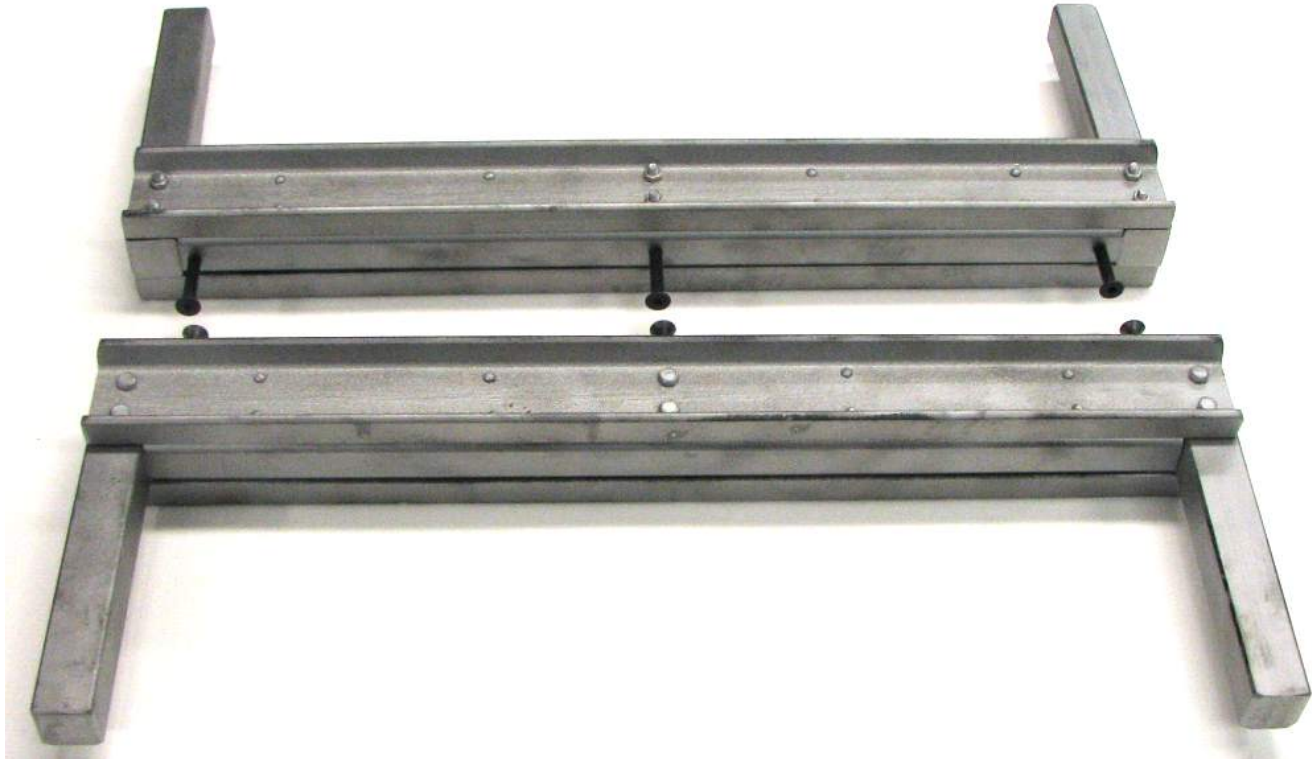
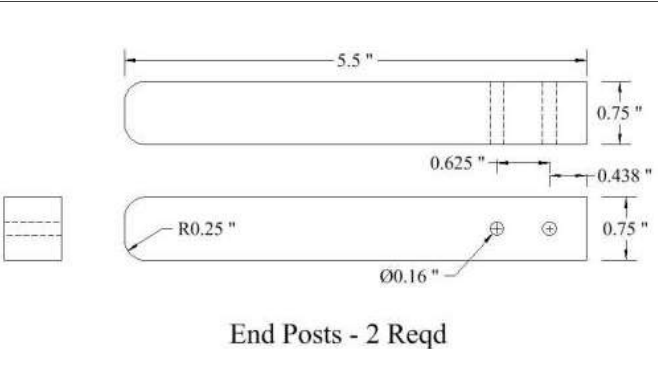

**Outside Log Bunk:**

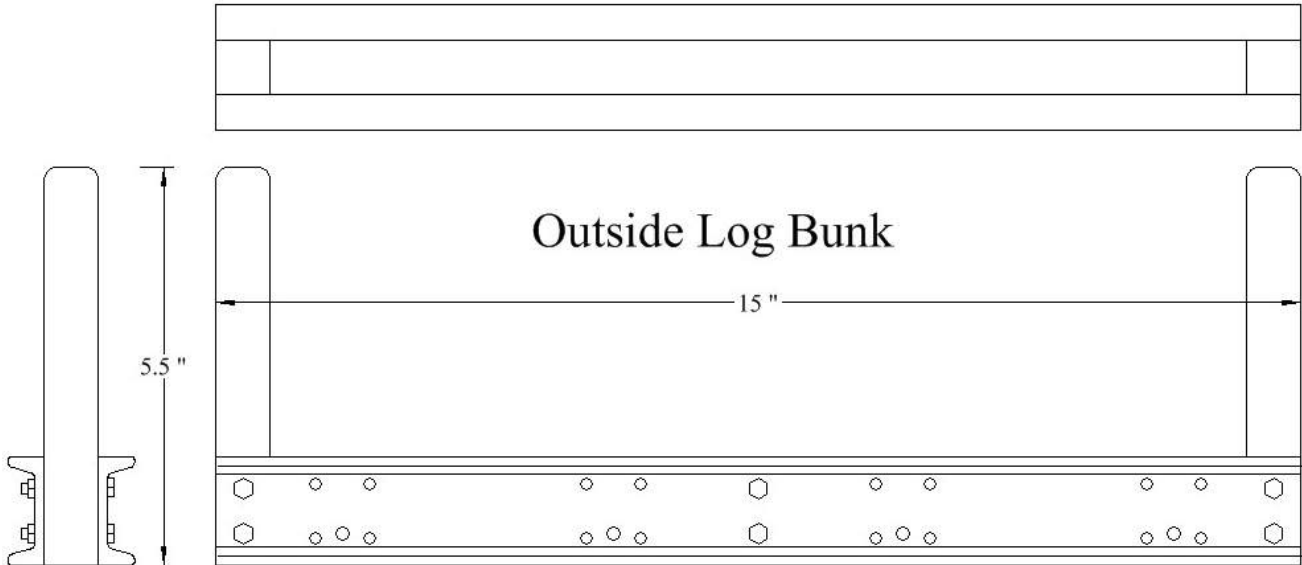

The drawing above shows the Outside Log Bunk which is identical to the Inside Log Bunk with the addition of holes for the ends of the Truss Rods and additional drive screws. The Ends Posts and Filler Tubes are identical to those on the Inside Log Bunks described above.

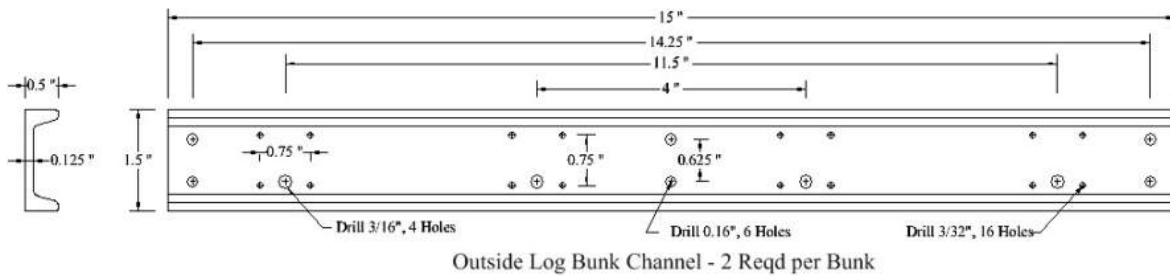

The Outside Log Bunk Channel with the additional holes is shown above. The drilling template shown in next photo was used to spot the holes in all the log bunk channels. The extra holes were covered with masking tape when the template was used for the Inner Log Bunks and the Log Bunks on the Disconnected Log Trucks.



The assembled Outside Log Bunks are shown in next photo. Note that an additional screw is used per Bunk to attach the bunks to the Car Tubes. The holes for the attachment screws were spotted, drilled and tapped using the same procedure described for the Inside Log Bunks. Note that a ~ 3/8" diameter hole is drilled in the middle of the under side for the head of the 10-23 SHCS used to attach the Truck Pin to the middle Car Tube. That screw head sticks up into the Filler Tube.



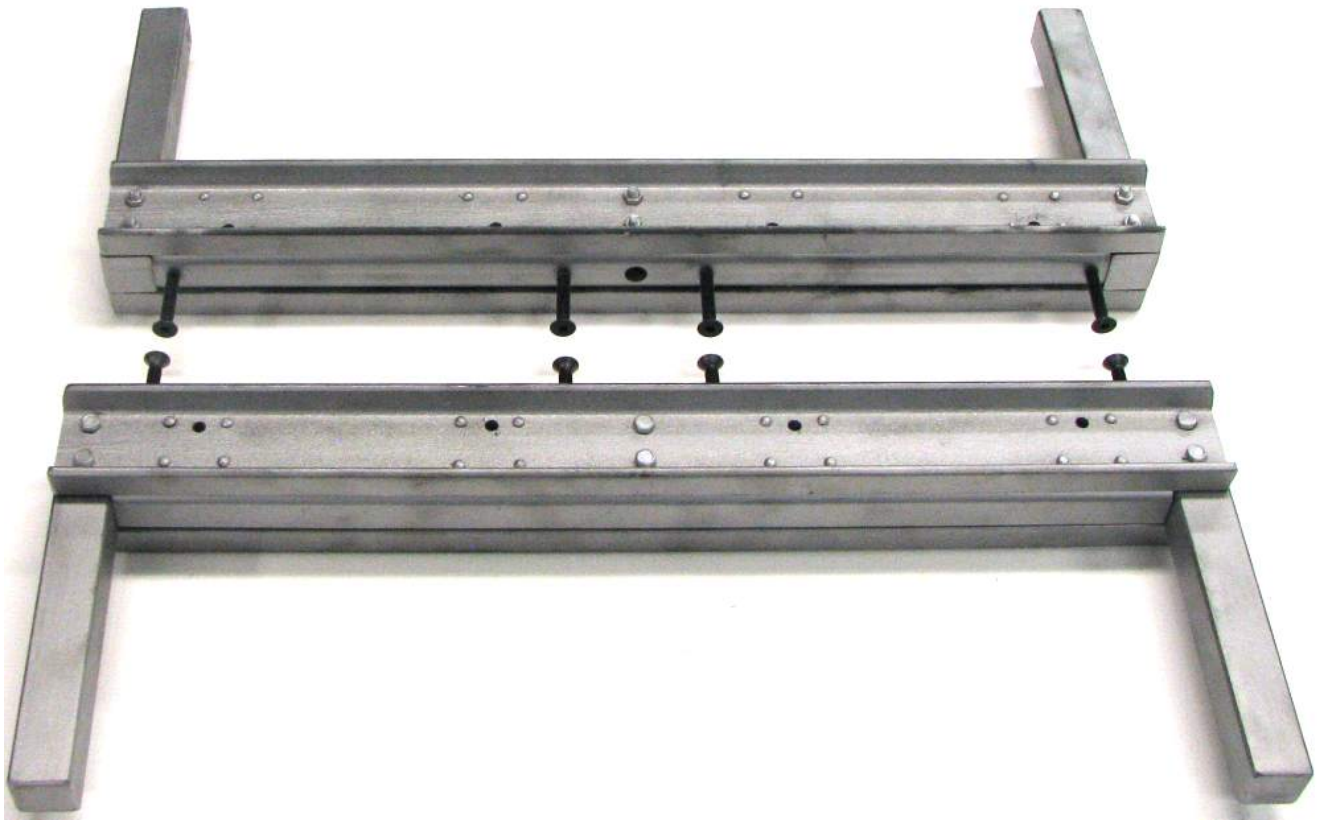

### I Beams:

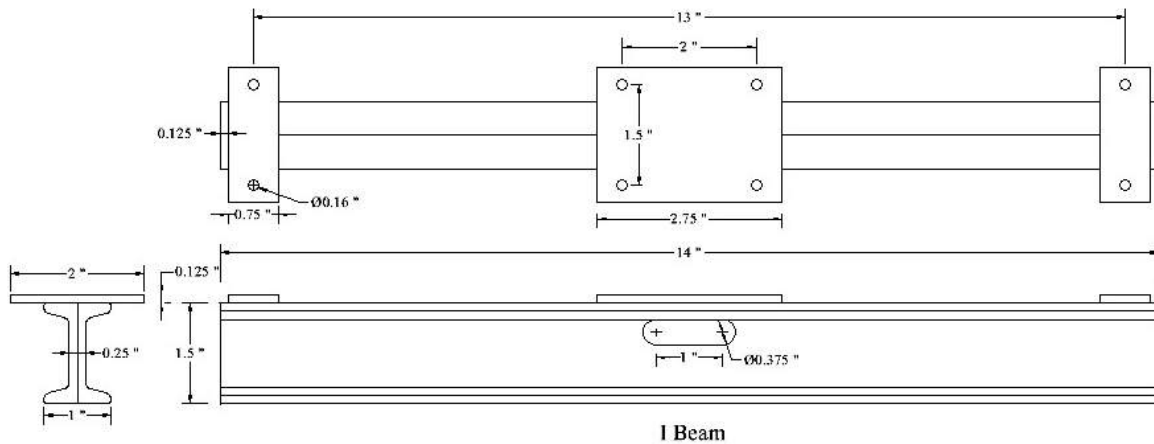

The I Beam was made by welding two of the 1 1/2" X 1/2" X 1/8" channels back-to-back. If welding is not available then the channels can be screwed together with a half dozen 4-40 button head cap screws on each side. The tabs are cut from 1/8" HRS bar stock and then welded to the channels. Again, if welding is not available, the tabs can be attached to the channels with a few 6-32 or 8-32 FH screws into the channel webs. The slot in the I Beam near the center is for the brake rod. The I Beams are attached to the car tubes with eight 8-32 hex head screws each. The I Beams are clamped to the correct position on the underside of the car tubes and the holes in the tabs used to spot the holes for the attachment screws. The holes in the tubes are then drilled and tapped 8-32. After the I Beams are attached the truss rods are test fitted and their location marked on the underside of the I Beams. Small slots are then made in the bottom of the I Beams using

the edge of a hand held grinder. The slots are visible in the bottom of the photo of the I Beams below

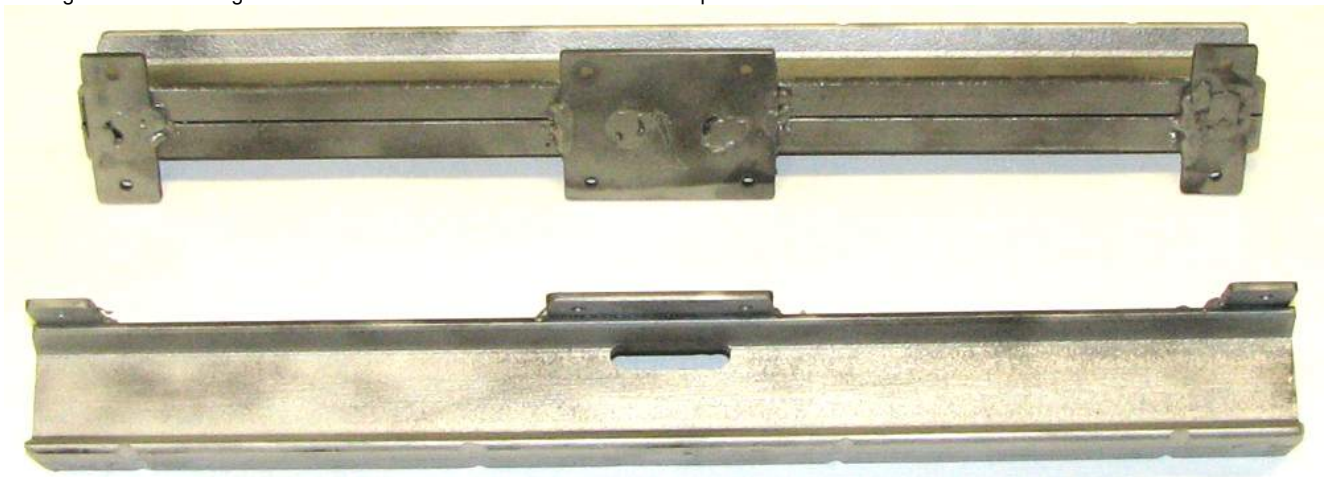

**Truss Rods:**

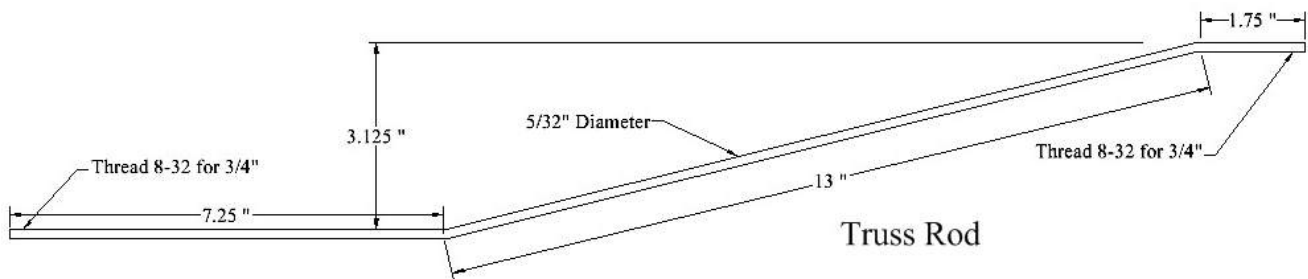

I used 3/16" rods on the first car built. They looked a bit over scale. Then I tried 1/8" and they looked way under scale so 5/32" rods threaded 8-32 was the next obvious choice. Unfortunately, inexpensive 5/32" CRS rod is not readily available. Enco has 5/32" drill rod for a little less than \$2 per 3' length so I tried that and was satisfied. I found aluminum turnbuckles for 5/32"-32 rod for a little over a dollar from McMaster-Carr (3010T14). One can use all RH thread by rethreading the one end of the turnbuckle. If that is done the turnbuckle is installed and first and the nuts at the end of the rods used to draw the rods tight. I wanted to use 8-32 threaded brake adjusters so I bought a 8-32 LH thread tap and die. Note that the 5/32"-32 threads on the turnbuckle at 0.156" diameter are slightly smaller than the 8-32 thread OD at ~0.160. I couldn't find inexpensive 5/32" taps and dies so I used 8-32. The turnbuckle threads are opened slightly with the 8/32 taps. The 8/32 dies seem to give sufficient thread depth on the 5/32" drill rod.

The rods were cut to 22' length and chucked in the lathe to thread the ends (die in tailstock). Half the rods were threaded 8-32 RH on both ends and half were threaded 8-32 RH on one end and 8-32 LH on the other end. The rods were bent in the vise making sure the ends with the LH threads were on the 7 1/4" length. Two rods were then screwed into the turnbuckle and the short ends fed through the holes in the Outside Log Bunks. The turnbuckles were adjusted so that the rod ends were about one third of the way in. The final tightening was done via the nuts on the rod ends --- didn't want to wear the threads in the aluminum turnbuckle



**Foot Pegs**



The photo above shows the foot peg assembly that is used in connection with a boat seat to make the log car also a riding car for one person. The pegs are Buddy Foot Pegs #17-1260 from [www.heeters.com](http://www.heeters.com). The male ends of the pegs are threaded 12X1.25 mm. The center bar is 3/4" square HRS 12.25" long with the ends drilled and tapped to match the foot peg studs. The cross pieces are 2.5" lengths of the 3/4" square HRS. The center bar is attached to the cross pieces with 10-32 SHCS, one per cross piece. The cross pieces are secured to the under side of the outer tubes of the center tube assembly with two 10-32 SHCS each. The assembly is positioned behind the wheels as shown in the photo below. Note that the foot peg assembly is very robust to take the extreme load placed on the foot pegs.



#### Log Load:



Tractor Supply 4"-5" diameter posts cut to 4' lengths were used for the logs as shown above. The logs are screwed together using 1" X 1/8" bar stock and 1/4" lag screws on the under side as shown in the next photo. The bars are positioned just inside of the outer log bunks. The load is secured with chains and turnbuckles like those described for the disconnected log trucks.



---

**Seat:** Frequently friends want to take a ride on the train so I decided to equip the log cars with boat seats as shown in the photo below. The seats were purchased at Wal-Mart.



The next photo shows the frame used to secure the seat. The tubes are 1" square X 1/16" wall that fit over the log bunk end posts. The flat bars are 1/4" X 2" HRS. The Tubes and Bars are welded together. The top of the logs were chiseled a little where necessary so that seat is level side-to-side. The seat is secured to the logs with a couple #12 wood screws through the holes in the front ends of the bars into the top logs. This seat is able to take the force of someone leaning back on the seat while pushing against the foot pegs.



The couplers and safety chains are discussed in a separate page.

[Small Projects Home](#)

[NLW Home](#)

